

CENTRAL MACHINERY®

10" AUTO PLANER

Model 41921

ASSEMBLY AND OPERATION INSTRUCTIONS



Due to continuing improvements, actual product may differ slightly from the product described herein.



3491 Mission Oaks Blvd., Camarillo, CA 93011

Visit our website at: <http://www.harborfreight.com>

TO PREVENT SERIOUS INJURY, READ AND UNDERSTAND ALL WARNINGS AND INSTRUCTIONS BEFORE USE.

Copyright® 1999 by Harbor Freight Tools®. All rights reserved. No portion of this manual or any artwork contained herein may be reproduced in any shape or form without the express written consent of Harbor Freight Tools.

For technical questions or replacement parts, please call 1-800-444-3353.

SPECIFICATIONS

Motor	115 V/60 Hz. 2.2 HP	Power Cord	5'9", 3-pole, UL listed
Amps	7.1 (no load)	Overall Dimensions	22" x 16" x 23-1/4"
Cuts per Minute	16,000	Weight	89.5 lb.
Cutter Head RPM's	8,000 (no load)	Cutting Capacity	
Cutting Knives	2, Bi-Metal, M-2 edge	Length of unbutted stock	8" minimum
Feed Rate	23 feet per minute	Width of stock	10" max.
Table Dimension	12-5/8"L x 10-1/4"W	Thickness of stock	1/4" - 5"
Sound Level	94 dB	Depth of cut	1/8" max.

Included Accessories

Combination wrench	Carbon Brush set
2 hex wrenches	Blade / Knife Gauge

Features

1. Adjustable extensions to support long workpieces.
2. Anti-kickback safety devices prevent workpieces from being ejected toward the operator.
3. Two bi-metallic blades are adjustable and replaceable for powerful cutting performance.
4. Compact and lightweight machine can plane workpieces up to 10" wide and 5" thick.
5. Positive adjusting table with crank handle and easy to read thickness gauge.
6. ON/OFF switch has removable safety lock device to prevent unauthorized use of the machine.
7. Integral circuit breaker protects the motor from burn out.

Save this manual

You will need the manual for the safety warnings and cautions, assembly instructions, operating procedures, maintenance procedures, trouble shooting, parts list, and diagram. Keep your invoice with this manual. Write the invoice number on the inside of the front cover. Keep both this manual and your invoice in a safe, dry place for future reference.

NOTICE

The Warnings, Cautions, and Instructions discussed in this instruction manual cannot cover all possible conditions and situations that may occur. It must be understood by the operator that common sense and caution are factors which cannot be built into this product, but must be supplied by the operator.

SAFETY WARNING & CAUTIONS

READ ALL INSTRUCTIONS BEFORE USING THIS TOOL!

1. **Warning!** Make sure blade is fastened and tightened down securely.

2. **Keep work area clean.** Cluttered areas invite injuries.
3. **Observe work area conditions.** Do not use tools in damp, wet, or poorly lit locations. Don't expose to rain. Keep work area well lit. Do not use electrically powered equipment in the presence of flammable gases or liquids.
4. **Keep children away.** Children must never be allowed in the work area. Do not let them handle machines, tools, or equipment.
5. **Store idle equipment.** When not in use, tools must be locked up in a dry location to inhibit rust. Always lock up tools and keep out of reach of children.
6. **Do not force the tool.** It will do the job better and more safely at the rate for which it was intended. Do not use inappropriate attachments in an attempt to exceed the tool's capacities.
7. **Use the right tool for the job.** Do not use a tool for a purpose for which it was not intended.
8. **Dress properly.** Do not wear loose clothing or jewelry, as they can be caught in moving parts. Non-skid footwear is recommended. Wear restrictive hair covering to contain long hair. Always wear appropriate work clothing.
9. **Use eye, ear, and breathing protection.** Always wear ANSI approved impact safety goggles if you are producing metal filings or wood chips. Wear an ANSI approved dust mask or respirator when working around metal, wood, and chemical dusts and mists. Use ANSI approved ear protection when working in a loud or noisy environment.
10. **Do not abuse the power cord.** Protect the power cord from damage, either from impacts, pulling or corrosive materials. Do not yank machine's cord to disconnect it from the receptacle.
11. **Do not overreach.** Keep proper footing and balance at all times. Do not reach over or across running machine.
12. **Maintain tools with care.** Keep tools sharp and clean for better and safer performance. Follow instructions for lubricating and changing accessories. Inspect power cord periodically and, if damaged, have it repaired by an authorized technician. Inspect all hydraulic seals for leaks prior to use. Control handle and power switch must be kept clean, dry, and free from oil and grease at all times.
13. **Remove adjusting keys and wrenches.** Be sure that keys and adjusting wrenches are removed from the tool or machine work surface before operation.
14. **Avoid unintentional starting.** Be sure that you are prepared to begin work before turning the start switch on.
15. **Stay alert.** Watch what you are doing. Do not operate this machine when you are tired.
16. **Do not operate this machine while under the influence of alcohol, drugs, or prescription medicines.**
17. **Check for damaged parts.** Before using any tool, any part that appears damaged should be carefully checked to determine that it will operate properly and perform its intended function. Check for alignment and binding of moving parts, any broken parts or mounting fixtures, and any other condition that may affect proper operation. Any part that is damaged should be properly repaired or replaced by a qualified technician. Do not use the tool if any switch does not turn on and off properly.
18. **Replacement parts and accessories.** When servicing, use only identical replacement parts intended for use with this tool. Replacement parts are available from harbor freight tools. Use of any other parts will void the warranty.

Special Warnings when using this Planing Machine

Using this Planer may create special hazards.

Take particular care to safeguard yourself and those around you.

1. **Electrical Safety. Never operate any tool if there is an electrical hazard.** Never operate an electrical tool in wet conditions. Never operate a tool with an improper electrical cord or extension cord. Never operate an electrical tool unless it is plugged into a properly grounded outlet, which supplies 110-120 Volts at 60 Hz. We recommend you use a circuit which is protected by an appropriate circuit breaker.
2. **Ejected Material. Use safe practices to avoid injury from ejected material.** Because the planer turns at high speed, there is a danger of being injured by materials that may be ejected. Always wear ANSI-certified eye protection. Always stand to one side of the line in which the materials are being inserted or extruded, to avoid being hit if particles are ejected. Never allow bystanders to be in the proximity of the Planer while in operation.
3. **Jamming. Avoid causing the planer to bog down or jam by avoiding the following situations.** Do not attempt to plane more than 1/8" at a time, or less if the wood is very hard. Do not attempt to feed more than the stated feed rate, or less if the wood is very hard. Be sure your knife blades are kept sharp. Check all workpieces for knots and foreign objects before planing. If the workpiece jams, it is likely the circuit breaker will break to protect the motor.
4. **Entanglement. Use extreme caution to prevent loose materials from being caught in the machine.** Never operate this Planer with loose clothing, long hair, jewelry, or other items which may become caught in the blades or workpieces. In case of entanglement, press the OFF switch immediately.
5. **People with pacemakers should consult their physician(s) before use.** Electromagnetic fields in close proximity to heart pacemaker could cause pacemaker interference or pacemaker failure.
6. **Some dust created by power sanding, sawing, grinding, drilling, and other construction activities, contains chemicals known [to the State of California] to cause cancer, birth defects or other reproductive harm.** Some examples of these chemicals are: Lead from lead-based paints Crystalline silica from bricks and cement or other masonry products Arsenic and chromium from chemically treated lumber. Your risk from these exposures varies, depending on how often you do this type of work. To reduce your exposure to these chemicals: work in a well ventilated area, and work with approved safety equipment, such as those dust masks that are specially designed to filter out microscopic particles. (California Health & Safety Code § 25249.5, et seq.)

NOTICE: No list of warnings can be all inclusive.

The operator must supply common sense, and operate this tool in a safe manner.

UNPACKING

1. Remove protective crating and materials carefully. In the event of damage in transit, contact Harbor Freight Tools. Be sure you have all small parts accounted for before discarding packing materials.
2. Check to be sure all parts are present. In addition to the planer, you should receive the accessories noted on page 2. You should also receive a crank handle, 2 carrying handles, and 2 table extensions, with their related hardware. If the 4 base brackets are not installed, they should be included, together with attaching hardware.

INSTALLATION

1. It is important that the machine be located on a solid, level platform. Find a location that has easy access to 110-120 Volt electrical service. Make sure this machine is located in a well lighted and well ventilated area. The floor should be resistant to vibration. There must be adequate room to insert and remove workpieces through the planer.
2. To permanently install the machine, check the platform to be sure it is even and level. Make any required corrections to the platform. If the base brackets are not attached to each lower corner of the machine, attach them using the supplied hardware. Mark and drill holes, and mount the machine using bolts and nuts.
3. If the machine will not be permanently installed, it is advisable to attach it to wooden skids by means of the base brackets. The skids should be solid hardwood at least 1" in thickness and 2" in width. Route these skids along each side of the machine from front to back. Each skid should extend several inches beyond the machine to allow them to be firmly clamped to the work surface before using the machine.

WARNING: Never operate this machine if it is not firmly attached to a work surface. If left unattached, the machine may move along the work surface possibly falling over, ejecting the work piece, or creating other hazards which can cause serious injury.

Electrical Power

This machine requires a 110-120V 60 Hz grounded power supply. This power is available in most common household or workshop outlets in the United States. Please observe the following safety precautions. (Note: Voltage variations of more than + or - 10% from the specification will result in noticeable reduction of service, and may cause damage to the motor).

1. Route the power cord in a way that avoids damage to the cord from other tools or machinery, and isolates the cord from exposure to wet or corrosive conditions.
2. Avoid routing cord along the floor, walkways, or halls, where it may cause a trip hazard.
3. Be sure the outlet is grounded and protected with an appropriate circuit breaker. Check with a qualified electrician if you have any doubts or concerns about your electrical service.
4. If you will use an extension cord, be sure to use a 3-prong, grounded cord. Preferably the cord will be UL listed. Know that long extension cords cause a noticeable power drop. It is necessary to use cords of the proper gauge to avoid excessive resistance or power drop within the cord. Please comply with the following table.

RECOMMENDED MINIMUM WIRE GAUGE FOR EXTENSION CORDS* (120 OR 240 VOLT)					
NAMEPLATE AMPERES (at full load)	EXTENSION CORD LENGTH				
	25 Feet	50 Feet	75 Feet	100 Feet	150 Feet
7.1 – 12.0	18	14	12	10	-
12.1 – 16.0	14	12	10	-	-
16.1 – 20.0	12	10	-	-	-

* Based on limiting the line voltage drop to five volts at 150% of the rated amperes.

Completing Assembly

WARNING: Unplug the machine before any assembly or adjustment.

Attaching the Carrying Handles

1. Locate the two carrying handles (349), and their hardware, Screws (327).
2. Attach the handles to the top of the machine firmly using the screws.

Installing the table extensions

1. With the roller up, place each table extension bracket (157) onto the table (125) and attach using two cap screws (164). Be sure the bracket assemblies are firmly attached, but are able to rotate up for storage.
2. Adjust each table extension so that a workpiece supported by the roller is level and in the same plane with the table. Do this by adjusting the cap screws (1) in or out as required. *See Figure 2.* Check the adjustment by placing a straight edge at least 24" long through the machine, and resting on the table and both extension rollers. When the extension is properly adjusted, lock the cap screws in place with the lock nuts (2).

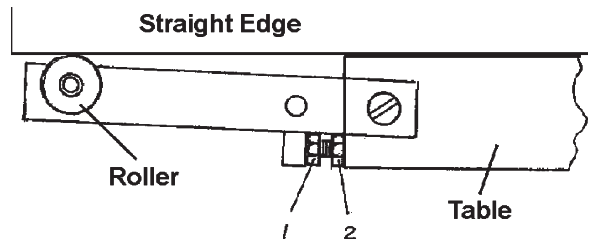

Figure 2. Table Extension Adjustment

Setting the Cutting Depth

1. Place the Table Adjustment Handle (150) over the square-ended Control Screw (130) which protrudes through the top of the machine.
2. Turn the Table Adjustment Handle to raise or lower the Table to the desired cutting thickness.
3. Read the cutting depth on the scale on the right of the machine.
4. Remove the Table Adjustment Handle before operating.

Operating the Power Switch

1. The power switch is on the lower right front of the machine.
2. The Safety Switch Cover must be in place to operate the Power Switch. You can remove the Cover and store it in a safe place to prevent unauthorized use.
3. Press the Switch UP to turn the machine ON, and DOWN to turn it OFF.

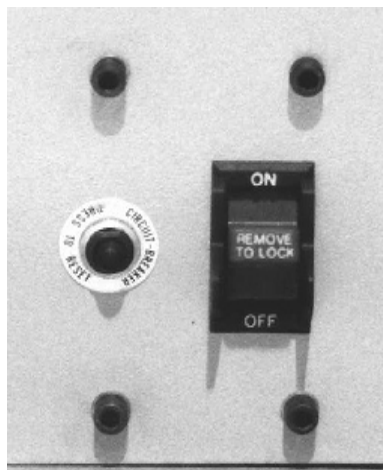

Fig. 4 Power Switch and Integral Circuit Breaker

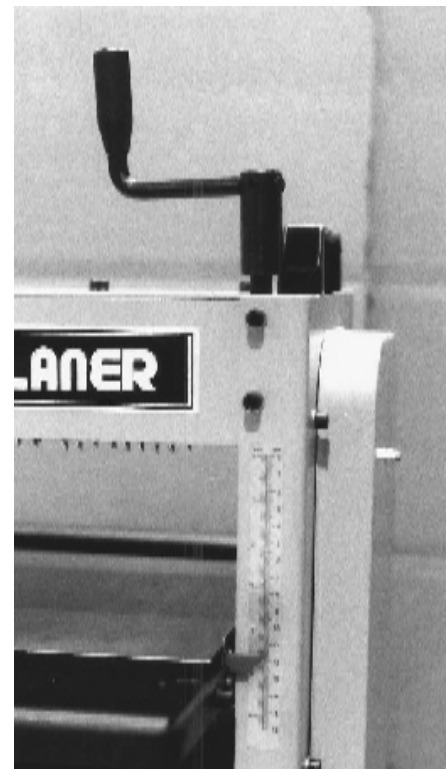

Fig. 3 Crank and Cutting Depth Scale

Integral Circuit Breaker

1. The circuit breaker trips if the amp draw exceeds 10 A., preventing motor burn out if the planer jams, or if there is a power surge.
2. To reset, correct the error condition and press the button back in.

SAFETY CHECK PRIOR TO OPERATION

WARNING: Unplug the machine and turn the power switch OFF before inspecting the machine.

1. Check to be sure all parts and fasteners are properly attached and tight.
2. Be sure the blade is properly installed and adjusted.
3. Check the operation of the Table Adjustment Handle (150). One rotation of the handle will raise or lower the table by 2mm (0.0787”).

Plug in the machine to prepare to check the motor and blade function.

1. Turn ON the machine by moving the switch up. *Note: The safety switch cover must be in place for the switch to operate.*
2. Do not insert any work materials into the planer. Allow it to spin up to full speed. Determine if the machine is operating smoothly, not making any excessive noises or vibrations. If not, the machine is ready to operate.

WARNING: CHECK BLADE SETTING AND TIGHTNESS BEFORE INITIAL USE.

OPERATION

WARNING: Wear ANSI-approved eye protection, and observe all safety precautions when operating.

1. Measure your workpiece to determine its current thickness, and the amount you desire to plane off. Maximum depth of cut is 1/8”; if you need to remove more than this, make repeated cuts.
2. Set the cutting depth by turning the Table Adjustment Handle (150) until the pointer indicates the correct depth on the scale.
3. *Turn the machine OFF and unplug the power cord.* Insert the workpiece into the planer and visually check your setting to assure that no more than 1/8” will be planed off the workpiece.

WARNING: Attempting to plane more than 1/8” at a time may cause the planer to jam; potentially causing the workpiece to splinter and be ejected from the machine, or the motor to jam and possibly burn out. Never plane more than 1/8” at a time.

4. When you are satisfied the cut is properly set up, remove the workpiece from the machine. Plug in the planer, and turn the power switch ON. Allow the planer to spin up to full speed.
5. Position the workpiece on the extension roller and table so that it is level. If you are planing a long board, you may need support tables on both sides of the planer to keep the workpiece level as its full length passes through the planer.
6. Feed the workpiece into the planer, no faster than the stated feed rate (23 feet per minute). The planer should maintain its speed. If the planer slows down noticeably, reduce the feed rate. If the planer still bogs down, remove the workpiece and adjust for a shallower cut.
7. Use a wooden pusher tool to push the board through the planer. You can also grip the finished portion of the workpiece, and pull it out of the planer.

WARNING: Keep hands farther away from intake than rollers on extensions.

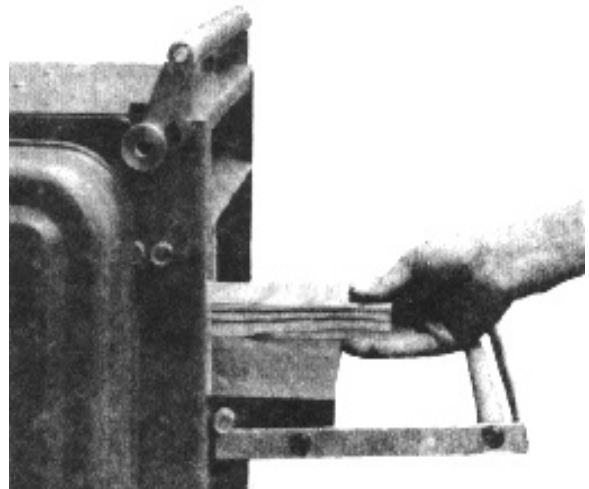

Fig 5. DO NOT Place Your Hand Inside the Extension Rollers

SUGGESTIONS FOR BETTER PLANING

This tool is ideal for finishing wood boards. You can use it to level or remove veneers. You can level warped boards. You can convert rough boards into finished wood. You can shape boards to a desired size.

Select your wood with care.

1. Be sure your wood is dry and properly cured. Green or wet wood will continue to shrink and may warp after planing.
2. Do not use splintered wood, or wood which may splinter while being worked. Some species such as Eucalyptus or Bamboo are prone to splintering and are not suitable for planing.
3. Do not use any boards with loose knots, or knots which are significantly harder than the surrounding wood. These can break out or come loose during planing, which can jam the machine.
4. Check your workpiece for foreign objects, such as nails, screws or stones which may be embedded in the wood. Remove any foreign objects before planing, or select another workpiece. Foreign objects may come loose and be ejected from the machine causing a hazard. Foreign objects may also damage the knife blades.

Plan the best way to handle warped and bowed boards.

1. Boards which are warped across the width of the board ("cupped" boards) should have the top planed flat first, then turned over and the bottom planed flat.
2. Depending on the width of the board, you can reduce waste in planing cupped boards by ripping them lengthwise first, then planing both resulting pieces.
3. Boards which are warped lengthwise ("bowed" boards) are difficult to successfully straighten out. The feed rollers in the planer will effectively straighten out bowed boards as they pass through. But the board will remain bowed when freestanding. If the bowed board cannot be used as is, it is best to select another board.



Figure 6. A Cupped Board

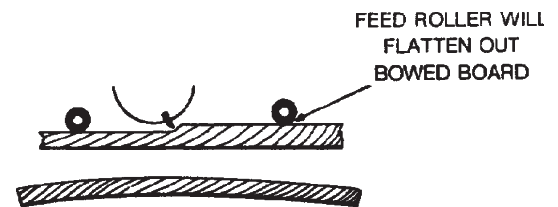

But bow will come back after planing
Figure 7. A Bowed Board

It is important to consider wood grain when planing.

1. It is best to cut in such a way that the planer's knife blades are cutting with the grain. This will reduce chipping, and result in a smoother finished surface. You can identify the grain direction by looking at the edge or end of the board. You can also often feel the grain with your fingers.
2. In some boards, the grain direction reverses part way along the board. If possible, cut such boards at the transition point, and plane each piece separately.

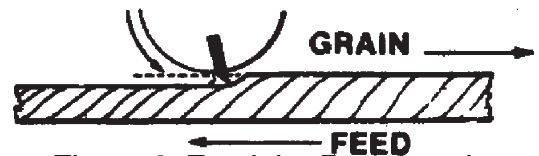

Figure 8. Feed the Board so the Knife Blades cut WITH the Grain

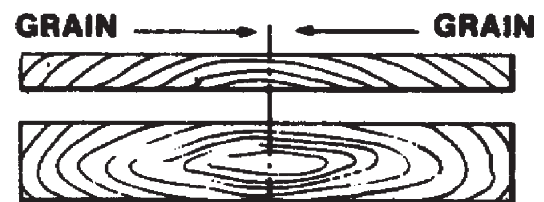

Figure 9. Boards Whose Grain Changes Direction in the Middle.

Avoiding Kickback.

1. Always insert boards for planing into the front of the machine. The insertion direction is indicated by the arrow on top of the left belt cover.
2. Anti-kickback devices are installed along the top edge of the front opening of the planer.

WARNING: Avoid kickback by never overloading the machine.

MAINTENANCE

When not in use, keep the machine unplugged and covered. Store it in a dry place. Store the safety switch cover in a safe place to prevent unauthorized use. Unplug the machine before doing any maintenance.

1. **Regular lubrication is required to keep your planer in good condition, and assure a long service life.**

Note: Do not apply grease to the belts.

- a. Keep the table guide rods clean, and coated with a light coat of grease.
 - b. Occasionally remove the top and apply a light grease to the bearings at each end of the cutter head. The motor bearings are sealed and do not require additional lubrication.
 - c. Remove the panels on both sides of the planer, and apply a light grease to the chains.
 - d. Apply a light coat of grease to the chain on the underside of the machine.
2. Keep the motor and electrical controls dry and clean. Keep the motor free of chips, sawdust, grease, and debris.

ADJUSTING THE CUTTING KNIVES

WARNING: Be sure the machine is turned OFF and UNPLUGGED before attempting any adjustments.

The Cutter Head assembly can be accessed by removing the cover from the top of the machine.

1. Remove the top cover (326) from the machine by removing the bolts securing it.
2. *Please refer to Figure 11 when checking knife adjustment.* Position the knife Gauge (E) on the cutter head and knife blade as shown. The gauge must contact the knife blade and the cutter head at all three points shown. The blade is adjusted too low if there is a visible space between the blade edge and the gauge. The knife blade is too high when the gauge rocks from side to side on the cutter head when contacting the knife blade.
3. To adjust the blade setting, loosen the locking nuts (A) just enough to allow the blade (C) to move against the Lock Bar (B). To raise the knife blade, turn adjustment screw (D) counter-clockwise. To lower the knife blade, turn the adjustment screw clockwise and press down on the blade.

Note: It is important that you adjust the blade along its entire length, so the blade has a consistent depth.

4. When the knife blade is properly adjusted, tighten the locking nuts (A) firmly to lock it in place. *Be sure these nuts are on tight. Re-check alignment to be sure the knife blade did not slip during tightening.*

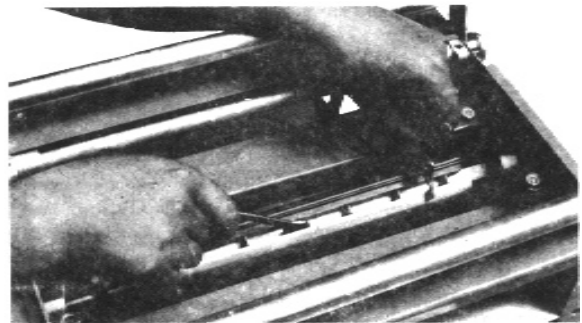

Figure 10. Checking the Knife Blade

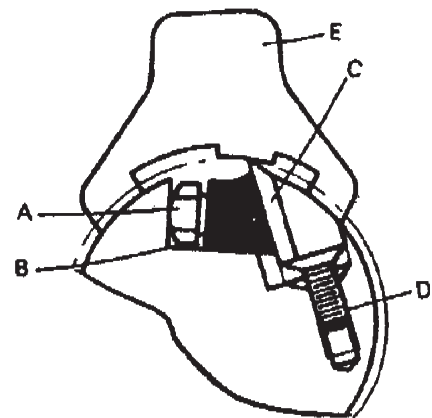

Figure 11. Knife Blade Gauge

TROUBLESHOOTING

Unplug the machine before attempting any repairs.

If the Planer runs roughly or has excessive vibration:

1. Verify that Knife Blades are not chipped, are securely installed, and are adjusted properly.
2. Verify that all chains and belts are properly routed on their pulleys and sprockets, and are not loose.
3. Verify that the Table is not damaged, and operates smoothly.
4. Be sure the Crank is removed from the Planer before operation.

If the Planer will not operate at all:

1. Verify that the planer is plugged in, the main circuit breaker in the power source is operational, and the integral circuit breaker on the machine is operational. If either circuit breaker is open, investigate further to determine and repair the cause of the fault.
2. Verify that the Planer is not jammed.
3. Inspect the carbon brushes in the motor to determine if they are in good condition.
4. Look for broken, damaged, or loose electrical connections. Repair before continuing.

If the Motor runs roughly or slowly:

1. Check for debris in the cutting assembly or in the chains or belts.
2. Inspect the carbon brushes, replace if necessary.
3. Verify that the power source supplies the correct Voltage and Amperage.

If the Planer cuts unevenly, poorly, or produces a rough or chipped finish:

1. Inspect the Knife Blades to be sure they are properly installed and adjusted.
2. Remove the Knife Blades and have them sharpened by a sharpening service.
3. Review the suggestions for selecting a workpiece, and adjusting the depth of cut.
4. Cut only with the wood grain.

Changing the Carbon Brushes:

1. Check carbon brushes every 10-15 hours of operation.
2. Brushes are accessed by turning the machine on its side. Motor is on machine's underside. The brush holders are on the sides of the motor. Remove brush holders by turning them with a coin.
3. Each brush has a line marked on its side. When the brush has worn to the line, or if it is cracked or chipped, replace both carbon brushes.

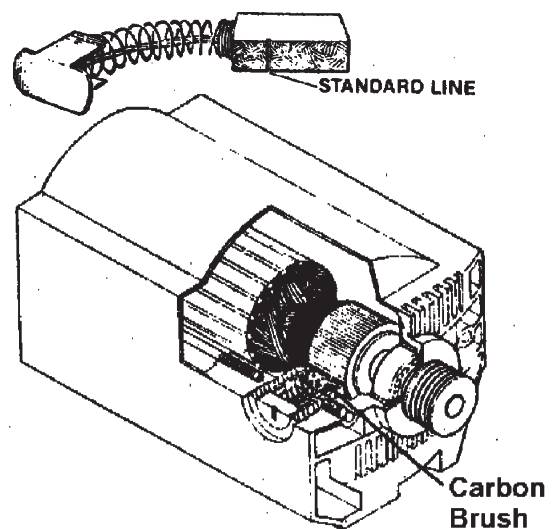

Figure 12. Checking and Replacing the Carbon Brushes

#41921 10" AUTO PLANER PARTS LIST, MAIN UNIT

Please refer to Parts Diagram on Page 12

Part	Description	Q'ty
101	Washer, m6	2
102	Cap Screw, m6 x 12	2
103	Screw, m6 x 50	1
104	Washer, m6	1
105	Retaining Ring, m15	1
106	Shaft	1
107	Sprocket	1
108	Retaining Ring, m15	1
109	Shaft	1
110	Pawl	15
111	Bushing	31
112	Washer, m6	4
113	Sprocket Cover	1
114	Cap Screw, m6 x 16	4
115	Screw Bolt	1
116	Frame	2
117	Sprocket, m16	3
118	Sprocket Frame	4
119	Sprocket	4
120	Washer, m10	4
121	Nut, m10	4
122	Washer, m8	2
123	Nut, m8	2
124	Sprocket Frame	4
125	Table	1
126	Side Guide	4
127	Screw, m5 x 10	8
128	Backing Board	1
129	Chain	1
130	Control Screw, m16	1
131	Pointer	1
132	Screw, m6 x 10	1

Part	Description	Q'ty
133	Wood Screw	4
134	Base Bracket	4
135	Cap Screw, m6 x 16	8
136	Nut, m6	8
137	Scale	1
138	Washer, m6	8
139	Screw, m6 x 16	8
140	Washer, m8	8
141	Right Cover	1
142	Bolt Screw, m8 x 50	2
143	Screw, m8 x 16	8
144	Switch Cover	1
145	Switch	1
146	Power Cord	1
147	Belt Cover	1
148	Washer, m6	2
149	Nut, m6	2
150	Table Adjustment Handle	1
151	Left Cover	1
152	Cap Screw, m8 x 20	8
153	Cap Screw, m8 x 16	4
154	Motor Cord	1
155	Circuit Breaker, 230V/10A	1
156	Strain Relief Bushing	1
157	Table Extension Bracket	2
158	Roller	2
159	Block	4
160	Cap Screw, m6 x 16	4
161	Pin, m8 x 20	4
162	Cap Screw, m6 x 20	4
163	Nut, m6	4
164	Screw, m8 x 16	4

PLEASE READ THE FOLLOWING CAREFULLY

THE MANUFACTURER AND/OR DISTRIBUTOR HAS PROVIDED THE PARTS DIAGRAM IN THIS MANUAL AS A REFERENCE TOOL ONLY: NETHER THE MANUFACTURER NOR DISTRIBUTOR MAKES ANY REPRESENTATION OR WARRANTY OF ANY KIND TO THE BUYER THAT HE OR SHE IS QUALIFIED TO MAKE ANY REPAIRS TO THE PRODUCT OR THAT HE OR SHE IS QUALIFIED TO REPLACE ANY PARTS OF THE PRODUCT: IN FACT THE MANUFACTURER AND/OR DISTRIBUTOR EXPRESSLY STATES THAT ALL REPAIRS AND PARTS REPLACEMENTS SHOULD BE UNDERTAKEN BY CERTIFIED AND LICENSED TECHNICIANS AND NOT BY THE BUYER. THE BUYER ASSUMES ALL RISK AND LIABILITY ARISING OUT OF HIS OR HER REPAIRS TO THE ORIGINAL PRODUCT OR REPLACEMENT PARTS THERETO, OR ARISING OUT OF HIS OR HER INSTALLATION OF REPLACEMENT PARTS THERETO.

#41921 10" AUTO PLANER PARTS DIAGRAM, MAIN UNIT

Please refer to Parts List on Page 11

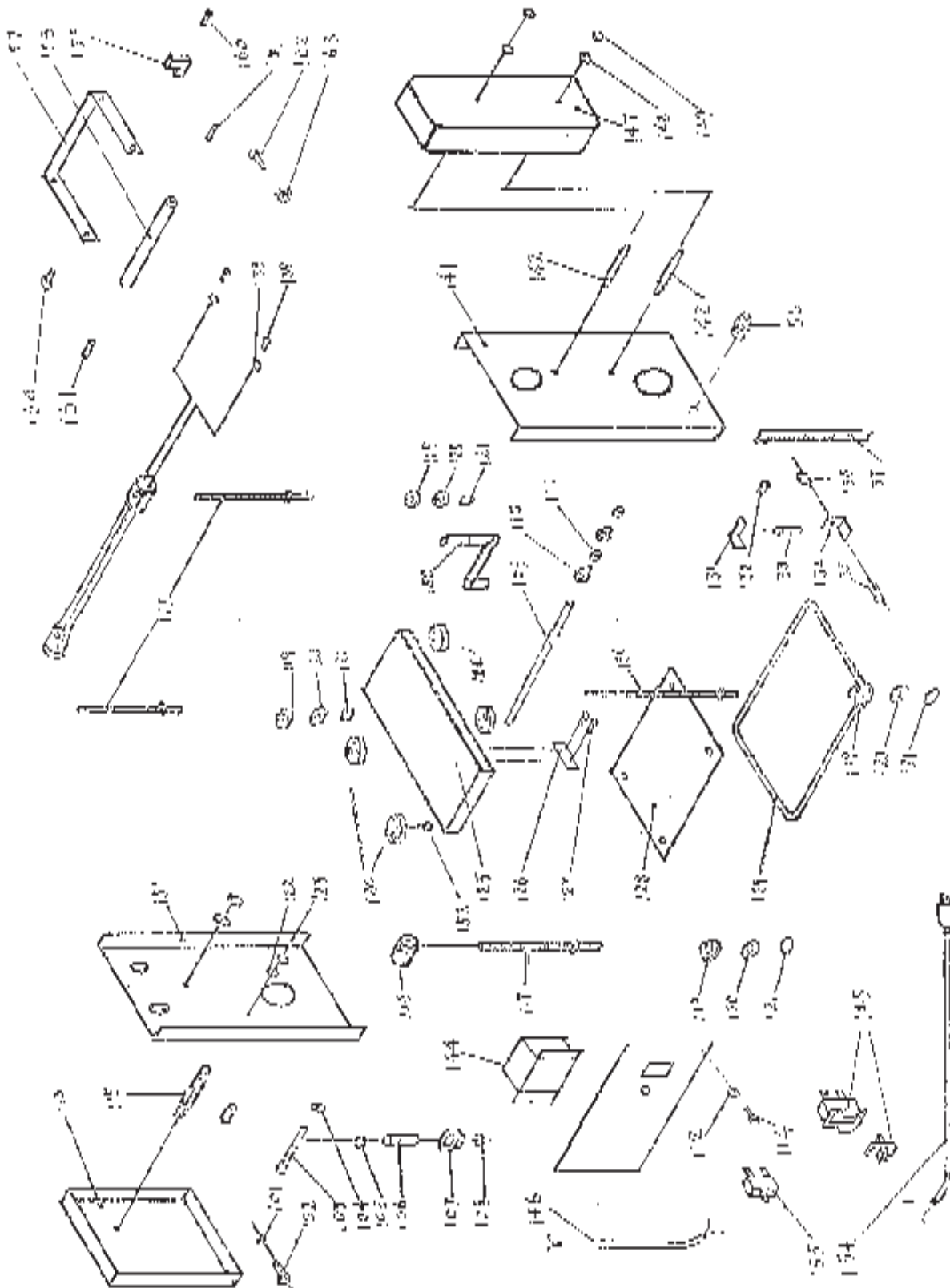

#41921 10" AUTO PLANER, ADDITIONAL PARTS LIST

Please refer to Parts Diagrams on Page 14 and 15

Part	Description	Q'ty
Motor Assembly		
201	Motor Housing	1
202	Stator	1
203	Washer, m5	1
204	Fan Casing	1
205	Screw, m5 x 85	2
206	Bearing, 6201ZZ	1
207	Silicone Steel Sheet	1
208	Bearing, 6029ZZ	1
209	Motor Pulley	1
210	Brush Holder	2
211	Carbon Brush	2
212	Brush Cap	2
213	Motor Box	1
214	Cap Screw, m5 x 12	4
215	Washer, m5	4
216	Pad Head Screw, m5 x 50	2
217	Pad Head Screw, m5 25	2
Cutter Assembly		
301	Frame Support	2
302	Screw	2
303	Girder Stay	2
304	Screw	1
305	Splash Apron	1
306	Spring	4
307	Roller Chain	1
308	Retaining Ring	6
309	Sprocket	4
310	Bushing	4
311	Free Roller	2
312	Tension Spring	1
313	Chain	1
314	Cap Screw, m6 x 22	8
315	Free Roller Bracket	2
316	Bearing, 60203ZZ	2

Part	Description	Q'ty
317	Cutter Head	1
318	Key, m5 x 5 x 20	1
319	Driven Pulley	1
320	Knife Gauge	1
321	Adjustable Bolt	4
322	Non-Belt, J-750-6	1
323	Nut, m16 x 1.5	2
324	Knife Lock Plate	2
325	Blade Knife	2
326	Top Cover	1
327	Screw, m8 x 20	4
328	Gear Box	1
329	Gear	1
330	Shaft	1
331	Steel Ball, m4	1
332	Steel Ball, m5	1
333	Pinion	1
334	Gear	1
335	Knife Lock Bolt	12
336	Collar	2
337	Pinion	1
338	Steel Ball, m4	1
339	Gear	1
340	Bearing, 6029ZZ	1
341	Bearing, 60202ZZ	1
342	Pinion Gear	1
343	Free Pully	1
344	Non-Belt, J-246-4	1
345	Face Screw	6
346	Axle	1
347	Collar	31
348	Pawl	30
349	Handle	2
350	Cover	1

#41921 10" AUTO PLANER PARTS DIAGRAM, MOTOR ASSEMBLY
 Please refer to Parts List on Page 13

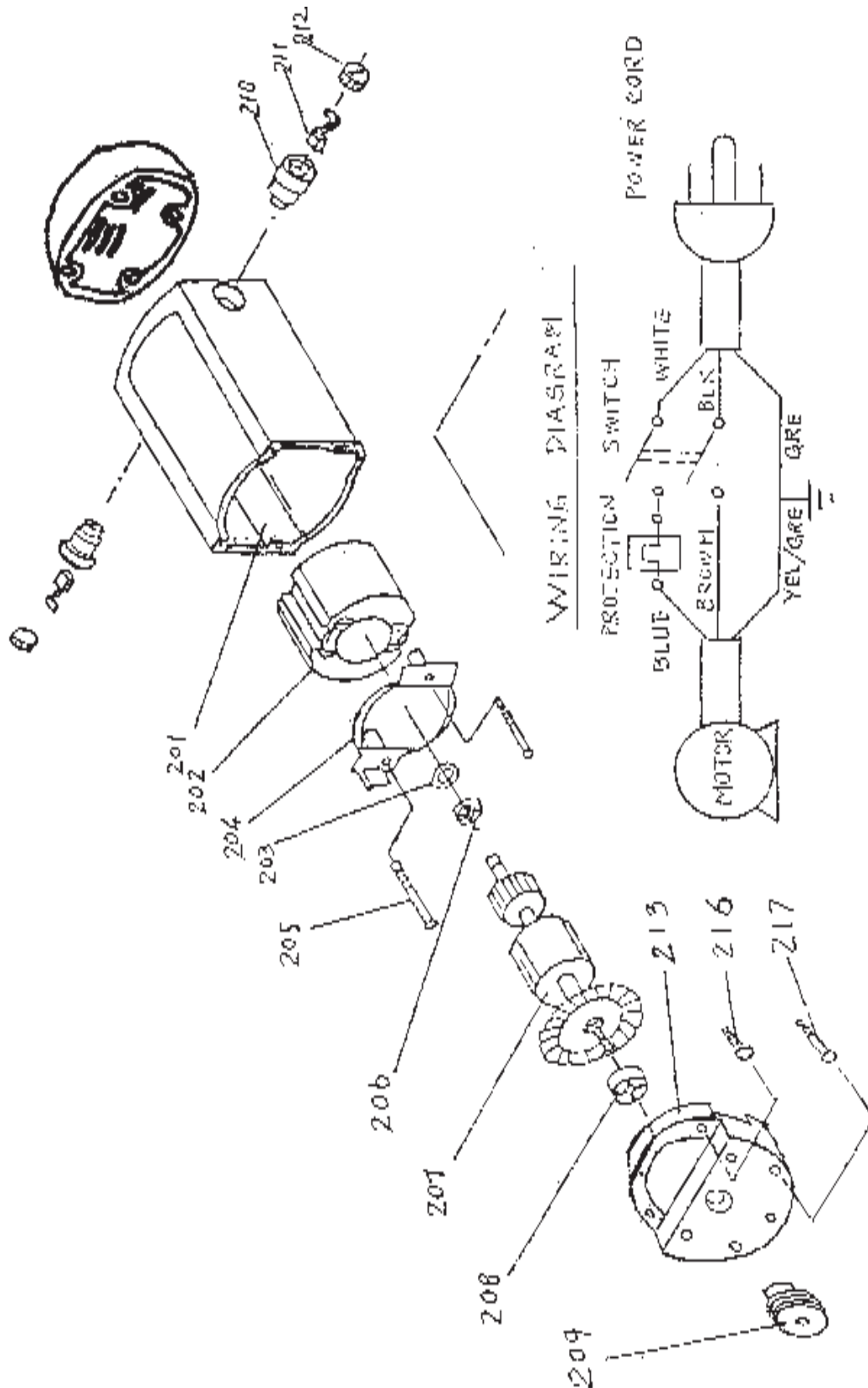

#41921 10" AUTO PLANER PARTS DIAGRAM, CUTTER ASSEMBLY

Please refer to Parts List on Page 13

